

Synthesis of n-scroll attractors using saturated functions from high-level simulation

To cite this article: J-M Muñoz-Pacheco and E Tlelo-Cuautle 2008 *J. Phys.: Conf. Ser.* **96** 012050

View the [article online](#) for updates and enhancements.

Related content

- [Automatic simulation of 1D and 2D chaotic oscillators](#)
E Tlelo-Cuautle and J-M Muñoz-Pacheco
- [Research on a family of n-scroll chaos generators](#)
G Zhang, S-Z Yang and L-F He
- [Generation and synchronization of N-scroll chaotic and hyperchaotic attractors in fourth-order systems](#)
Yu Si-Min, Ma Zai-Guang, Qiu Shui-Sheng et al.

Recent citations

- [C. Sanchez-Lopez et al](#)

Synthesis of n-Scroll Attractors using Saturated Functions from High-Level Simulation

Jesús-Manuel Muñoz-Pacheco, Esteban Tlelo-Cuautle¹

Department of Electronics, INAOE, Luis Enrique Erro No. 1, Tonantzintla, Puebla, 72840 MEXICO.

E-mail: mpacheco@inaoep.mx, e.tlelo@ieee.org.

Abstract. Modeling and simulation of a chaotic oscillator based on saturated nonlinear functions (SNLFs) are presented for the synthesis of n-scrolls attractors. First, the oscillator is simulated at the electronic system level by applying state variables and piecewise-linear approximation. Second, the dynamic ranges are scaled to control the breaking points and slopes within practical values. Additionally, the frequency scaling of n-scrolls attractors is performed. Finally, the SNLF is synthesized using operational amplifiers to generate 2, 3, 4, 5 and 6-scrolls attractors. Theoretical results are confirmed by SPICE simulations to show the usefulness of the proposed synthesis approach.

1. Introduction

The electronic design automation (EDA) industry has always had a major shift when a new language is used to design electronic systems. Recently, much of the EDA community has hyped Electronic System Level (ESL) languages as the new frontier. The EDA industry is enhancing its design tools for the digital domain where it covers the modeling, simulation and synthesis of digital systems from the ESL down to the transistor level. On the other hand, automated synthesis of analog systems from a description of its desired behavior, i.e. at the ESL, has not progressed to the point where it is practical except in a few very restricted cases [1]. Furthermore, this work introduces a new synthesis approach to design n-scrolls attractors [2-3], by beginning with ESL simulations [4-8], and ending with the synthesis of each individual block using operational amplifiers (opamps).

To speed-up time simulation, the chaotic oscillator is modeled by applying state variables [4], and piecewise-linear (PWL) approximation [9-10]. When the saturated nonlinear functions (SNLFs) have been computed, they can be synthesized using opamp high-level SPICE models [5]. Furthermore, although the majority of the research efforts have been focused to design Chua's circuit [11-12], and some variants of it to generate n-scrolls attractors, our proposed approach is oriented to synthesize chaotic oscillators based on SNLFs using opamps.

2. ESL modeling of the n-scrolls chaotic oscillator

A SNLF can be modeled using PWL approximations, e.g. the behavior of the opamp can be modeled using SNLFs [9]. In figure 1 is shown a SNLF with 7 and 5-segments to generate multiscrolls. In (1) is described a PWL approximation called series of a SNLF, where $k \geq 2$ is the slope of the SNLF and

¹ To whom any correspondence should be addressed.

multiplier factor to saturated plateaus, $plateau = \pm nk$, with $n = integer\ odd$ to even-scrolls and $n = integer\ even$ to odd-scrolls. $h =$ saturated delay of the center of the slopes in figure 1, and must agree with $hi = \pm mk$, where $i = 1, \dots, [(scrolls-2)/2]$ and $m = 2, 4, \dots, (scrolls-2)$ to even-scrolls; and $i = 1, \dots, [(scrolls-1)/2]$ and $m = 1, 3, \dots, (scrolls-2)$ to odd-scrolls. p and q are positive integers. To generate n -scrolls attractors a controller is added as shown in (2), where $f(x; k, h, p, q)$ is defined by (3), and a, b, c, d are positive constants and must be $0 < a, b, c, d < 1$ to accomplish chaos conditions [2].

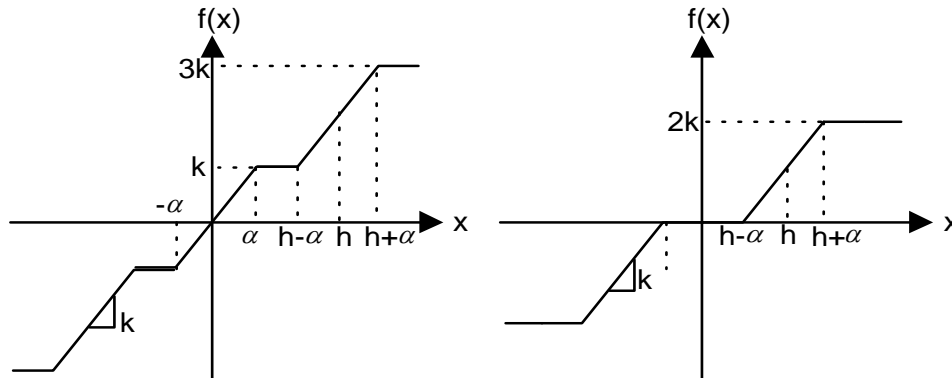

Figure 1. PWL description of a SNLF with 7 and 5-segments.

$$f(x; k, h, p, q) = \sum_{i=-p}^q f_i(x; k, h) \quad (1)$$

$$\begin{aligned} \dot{x} &= y \\ \dot{y} &= z \\ \dot{z} &= -ax - by - cz + df(x; k, h, p, q) \end{aligned} \quad (2)$$

$$f(x; k, h, p, q) = \begin{cases} (2q+1)k & x > qh+1 \\ k(x-ih) + 2ik & |x-ih| \leq 1, -p \leq i \leq q \\ (2i+1)k & ih+1 < x < (i+1)h-1, -p \leq i \leq q-1 \\ -(2p+1)k & x < -ph-1 \end{cases} \quad (3)$$

In (2) there are $2(p+q)+3$ and $2(p+q)+1$ equilibrium points located on the x axis to generate even and odd scrolls, respectively. They can be classified in saddle points of index 1 and saddle points of index 2. Since the scrolls are generated only around the saddle points of index 2 [2], (2) has the potential to generate $(p+q+2)$ -even scrolls and $(p+q+1)$ -odd scrolls. However, the $(p+q+1)$ and $(p+q)$ saddle points of index 1 are responsible to connect the $(p+q+2)$ -even scrolls and $(p+q+1)$ -odd scrolls, respectively, to generate the attractor. Additionally, the saddle points of index 2 correspond to a unique saturated plateau in (1), and to a unique attractor, while the saddle points of index 1 correspond to a unique saturated slope, and to a unique connection among the neighbors-scrolls.

3. Numerical simulation of n -scrolls attractors

The ESL simulation of the n -scrolls attractors modelled by (2) and (3), is executed using [4], [6-7]. 3-scrolls attractors are generated by setting $a=b=c=d=0.7$, $k=10$, $h=10$, $p=q=1$ to evaluate (2) and (3); and 6-scrolls attractors are generated with $a=b=c=d=0.7$, $k=10$, $h=20$, $p=q=2$, as shown in figure 2. As one sees, figure 2(a) shows that the dynamic ranges (DRs) are $x(-40,40)$, $y(-15,15)$ and $x(-60,60)$, $y(-15,15)$, respectively. Since real electronic devices cannot handle these DRs, (3) cannot be synthesized

and it cannot have small DRs because $k \geq 2$ [2]. Consequently, $h=2k$ or $h=k$ for even or odd scrolls, respectively, to avoid superimposing of the slopes because the plateaus can disappear. Henceforth, α is restricted to 1, so that to implement n -scrolls attractors using practical opamps one needs to scale DRs of the SNLF [2]. Then, the SNLF series is redefined by (4), where α allows that $k < 1$ because the chaos-condition now applies on $s=k/\alpha$, the new slope. In this manner, k and α can be selected to permit $k < 1$, so that DRs in (3) can be scaled. As a result, 3-scrolls attractors are now generated by setting $a=b=c=d=0.7$, $k=245e-3$, $\alpha=2.45e-3$, $s=100$, $h=245e-3$, $p=q=1$ to evaluate (2) and (4), and 6-scrolls attractors are generated with $a=b=c=d=0.7$, $k=245e-3$, $\alpha=2.45e-3$, $s=100$, $h=490e-3$, $p=q=2$, as shown in figure 2. Now, the DRs of the attractors are within the DRs of real opamps. Besides, it is possible to have small DRs depending on the values of k and α .

$$f(x; \alpha, k, h, p, q) = \begin{cases} (2q+1)k & x > qh + \alpha \\ \frac{k}{\alpha}(x - ih) + 2ik & |x - ih| \leq \alpha, -p \leq i \leq q \\ (2i+1)k & ih + \alpha < x < (i+1)h - \alpha, -p \leq i \leq q-1 \\ -(2p+1)k & x < -ph - \alpha \end{cases} \quad (4)$$

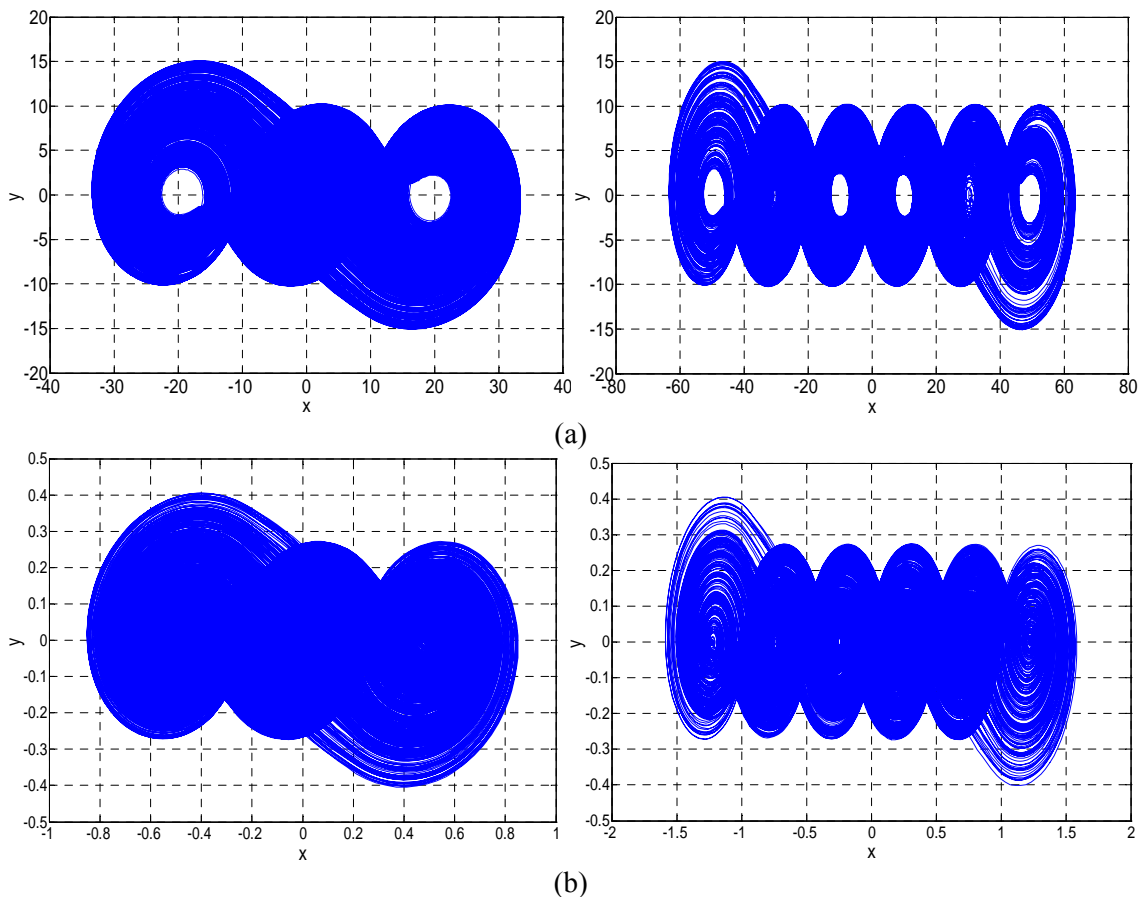

Figure 2. 3- and 6-scrolls attractors, (a) without DR scaling and (b) with DR scaling.

4. Circuit synthesis, frequency scaling and voltage and current SNLFs

The system in (2) has the block diagram representation given in figure 3(a), which is realized with 3 integrators. Each block can be synthesized with opamps, as shown in figure 3(b). The operator (+) is realized by adding currents in a node. By applying Kirchoff's current-law in figure 3(b) one obtains

(5), where $SNLF=i(x)R_{ix}$. The parameters in (5) are determined by (6). If $R_{ix}=10K\Omega$, then $C\approx 143\mu F$, $R=7K\Omega$, $R_x=R_y=R_z=10K\Omega$, $R_f=10K\Omega$ and $R_{in}=10K\Omega$, which describes the same system given in (2).

$$\frac{dx}{dt} = \frac{y}{RC}$$

$$\frac{dy}{dt} = \frac{z}{RC} \tag{5}$$

$$\frac{dz}{dt} = -\frac{x}{R_x C} - \frac{y}{R_y C} - \frac{z}{R_z C} + \frac{[i(x)R_{ix}]}{R_{ix} C}$$

$$C = \frac{1}{0.7R_{ix}}, \quad R_x = R_y = R_z = \frac{1}{0.7C}, \quad R = \frac{1}{C} \tag{6}$$

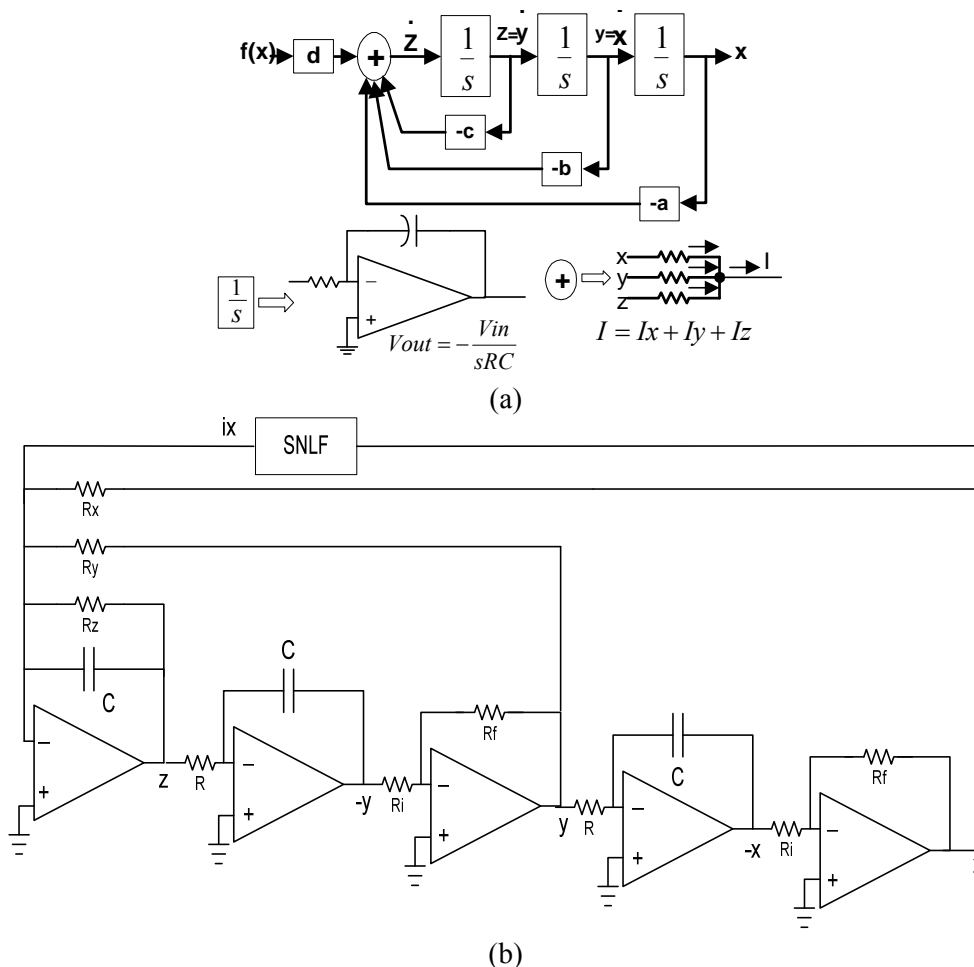

Figure 3. (a) Block diagram description of (2), and (b) its opamp-based implementation.

The frequency scaling consists in multiplying (2) by a required factor of scaling, and it is done on capacitor C in (5) to evaluate $C_{fs}=C/factor$. The frequency scaling is limited by the finite bandwidth of

the opamps in figure 3(b). In this manner, the opamp finite-gain model is shown in figure 4(a) [10], so that a voltage SNLF can be described by $V_o = \frac{Av}{2} \left(\left| V_i + \frac{Vsat}{Av} \right| - \left| V_i - \frac{Vsat}{Av} \right| \right)$, and if a shift-voltage ($\pm E$) is added, one gets the shifted-voltage SNLFs determined by (7) for positive and negative shifts, respectively. Now, $\alpha = Vsat/Av$ are the breakpoints, $k = Vsat$ is the saturated plateau, and $s = Vsat/\alpha$ is the saturated slope. A resistor can be added to realize a current-to-voltage transformation, e.g. $i_o = V_o/R_c$. To generate a SNLF (in figure 3(b)), E takes different values in (7) to synthesize the required plateaus and slopes. The cell shown in figure 4(b) is used to synthesize voltage and current SNLFs from (7). The value of the plateaus k , in voltage and current, the breakpoints α , the slope and h are evaluated by (8).

$$V_o = \frac{Av}{2} \left(\left| V_i + \frac{Vsat}{Av} - E \right| - \left| V_i - \frac{Vsat}{Av} - E \right| \right) \quad V_o = \frac{Av}{2} \left(\left| V_i + \frac{Vsat}{Av} + E \right| - \left| V_i - \frac{Vsat}{Av} + E \right| \right) \quad (7)$$

$$k = RixIsat, \quad Isat = \frac{Vsat}{Rc}, \quad \alpha = \frac{Ri|Vsat|}{Rf}, \quad s = \frac{k}{\alpha}, \quad h = \frac{Ei}{\left(1 + \frac{Ri}{Rf}\right)} \quad (8)$$

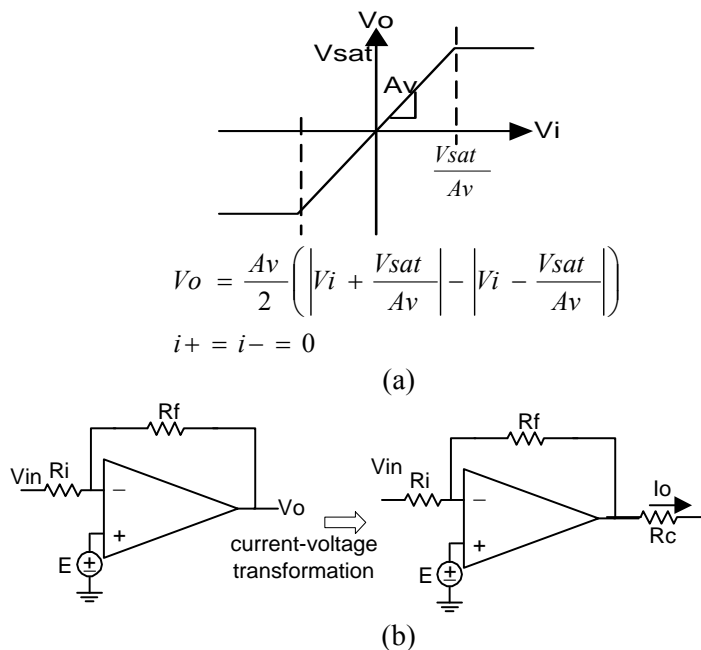

Figure 4. (a) Opamp finite-gain model, and (b) basic cell to generate SNLFs.

5. Synthesis of n-scroll attractors

The ESL speeds-up time simulation [4-7], since it allows the use of behavioral models for nonlinear systems instead of handling complex SPICE transistor models [1]. However, it is worthy to know practical DRs in order to synthesize chaotic oscillators with real opamps. For instance, the cell in figure 4(b) can synthesize the SNLF in (4), and the number of basic cells (BC) is determined by $BC = (\text{number of scrolls}) - 1$, which are parallel-connected as shown in figure 5(a). If $Vsat = \pm 2.45V$ (typical value for opamp TLC2262 with $Vdd = \pm 2.5V$ [13]), $Rix = 10K\Omega$, $Rc = 100K\Omega$, $Rin = 1K\Omega$ and $Rf = 1M\Omega$, in (8) one gets $k = 245mV$, $Isat = 24.5\mu A$, $\alpha = 2.45mV$, $s = 100$ and $h \approx Ei$. The saturated plateaus

and slopes are determined from section 2. Furthermore, the synthesis results for 2,3,4,5 and 6-scroll attractors are shown in figure 5 to figure 7; with $E_i=0$ to 2-scrolls, $E_1=k=245\text{mV}$ to 3-scrolls, $E_1=2k=490\text{mV}$ to 4-scrolls, $E_1=k=245\text{mV}$ and $E_2=3k=735\text{mV}$ to 5-scrolls, and $E_1=2k=490\text{mV}$ and $E_2=4k=980\text{mV}$ to 6-scrolls.

By selecting a frequency-scaling factor one gets C_{sf} , the new value to C in (5). For $C=143\mu\text{F}$, the frequency spectrum of figure 7(b) is shown in figure 8(a) where $f_{out}=0.154\text{ Hz}$. For the scaling factors of 9533 and 71500, C is updated to 15 nF and 2 nF , and $f_{out}=1.41\text{ kHz}$ and $f_{out}=11.1\text{ kHz}$, as shown in figure 8(b) and figure 8(c), respectively. As a conclusion, high-level simulation (ESL) is quite useful to explore on the practical values of the circuit elements, DRs and frequency scaling, to synthesize n -scrolls attractors using real opamps to implement SNLFs.

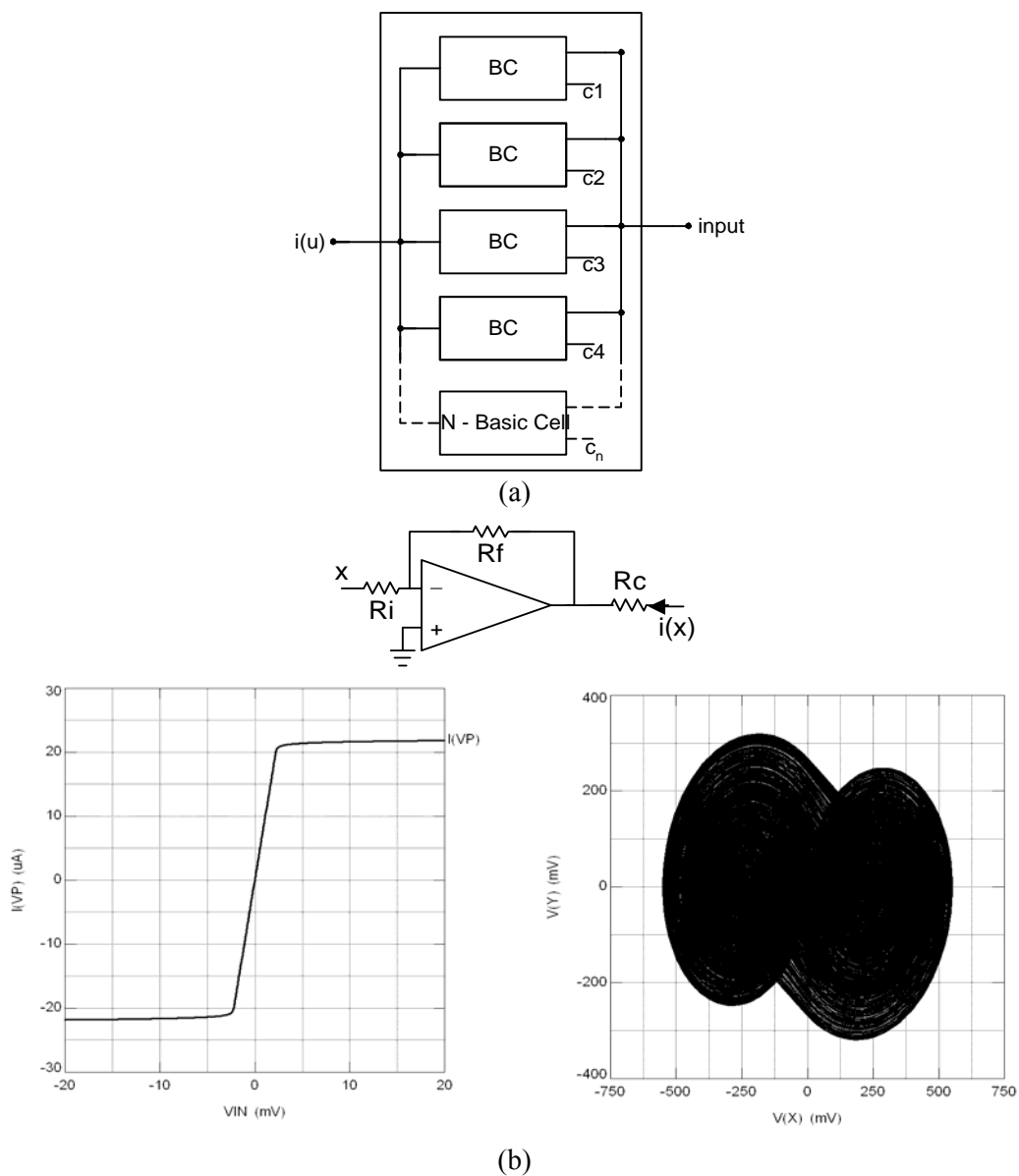

Figure 5. (a) Structure to synthesize SNLFs, and (b) synthesis of 2-scroll attractors.

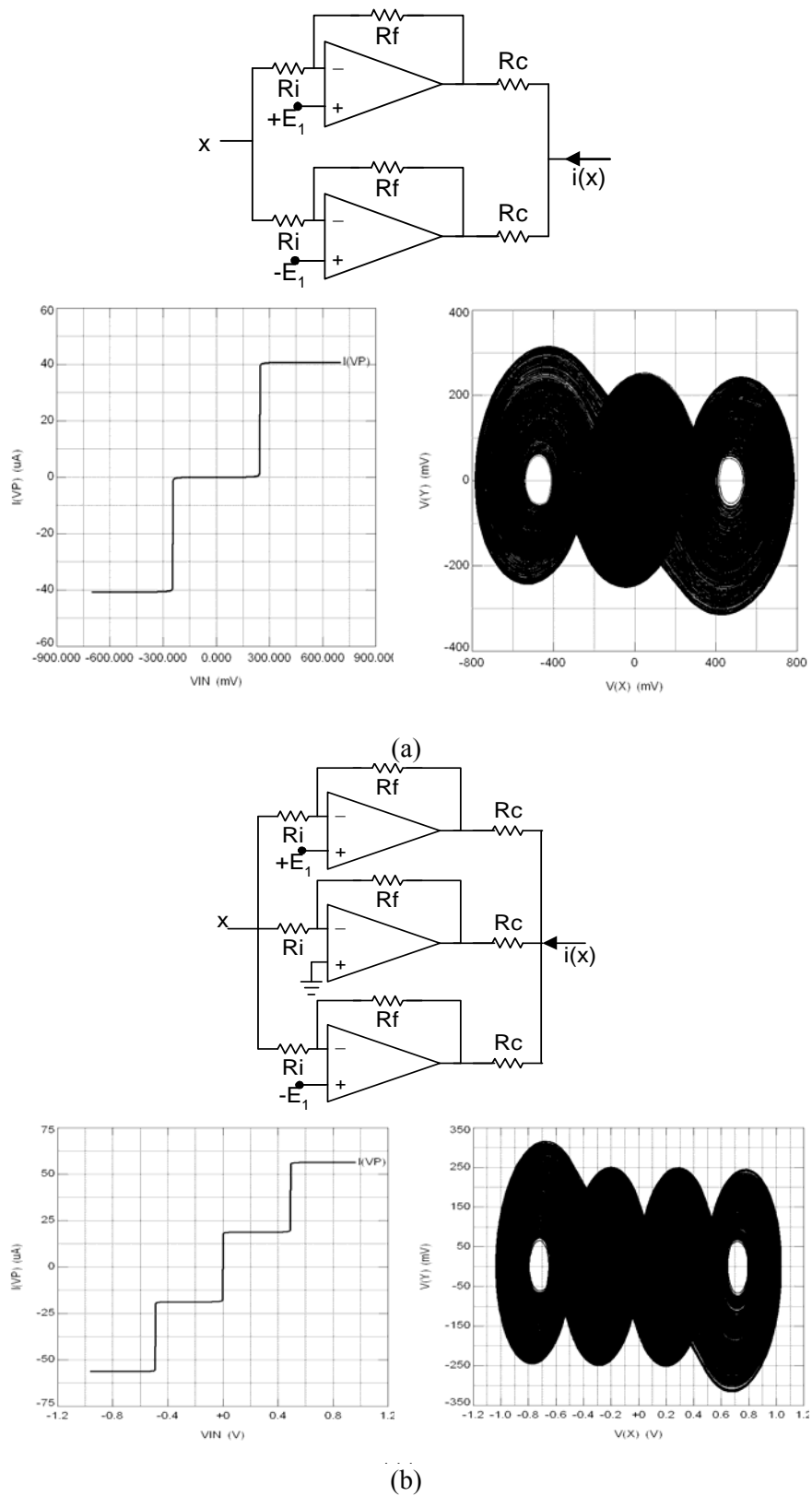

Figure 6. Synthesis of (a) 3-scroll, and (b) 4-scroll attractors.

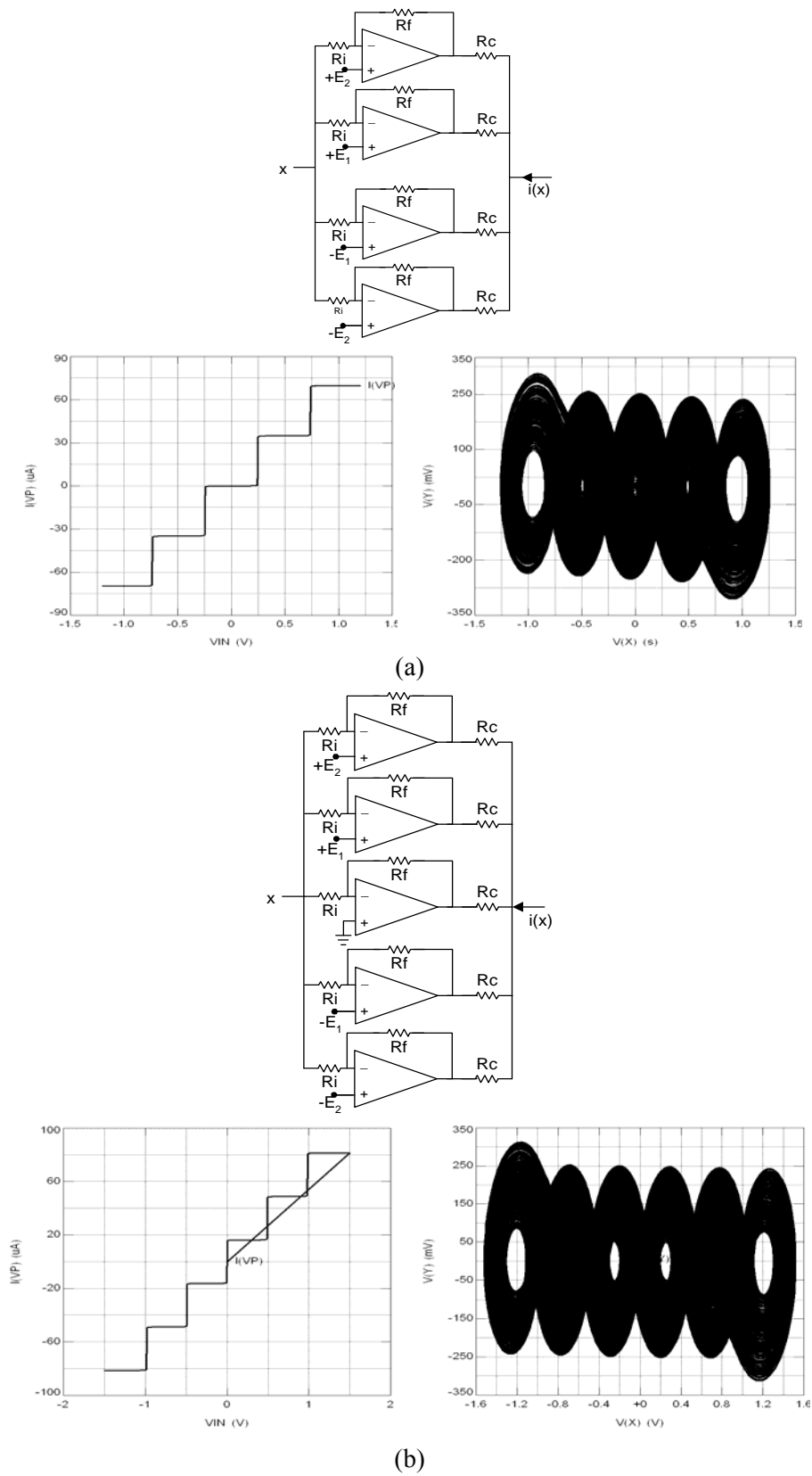

Figure 7. Synthesis of (a) 5-scroll, and (b) 6-scroll attractors.

6. Conclusion

It has been shown the simulation of n-scrolls chaotic attractors at the ESL to speed-up time simulation. The n-scrolls chaotic oscillator was modelled by state variables and PWL approximations. Furthermore, the synthesis of 2, 3, 4, 5 and 6-scrolls attractors using practical opamps is focused to implement PWL approximations by scaling DRs and frequency. In this manner, it was shown that SNLFs can be synthesized with real opamps by controlling the breaking points and slopes. Also, it has been shown the frequency-spectrum simulation of 6-scrolls attractors without and with frequency scaling. Finally, SPICE simulations are in good agreement with the high-level numerical simulations.

Acknowledgments

This work is supported by CONACyT/MEXICO under the project number 48396-Y.

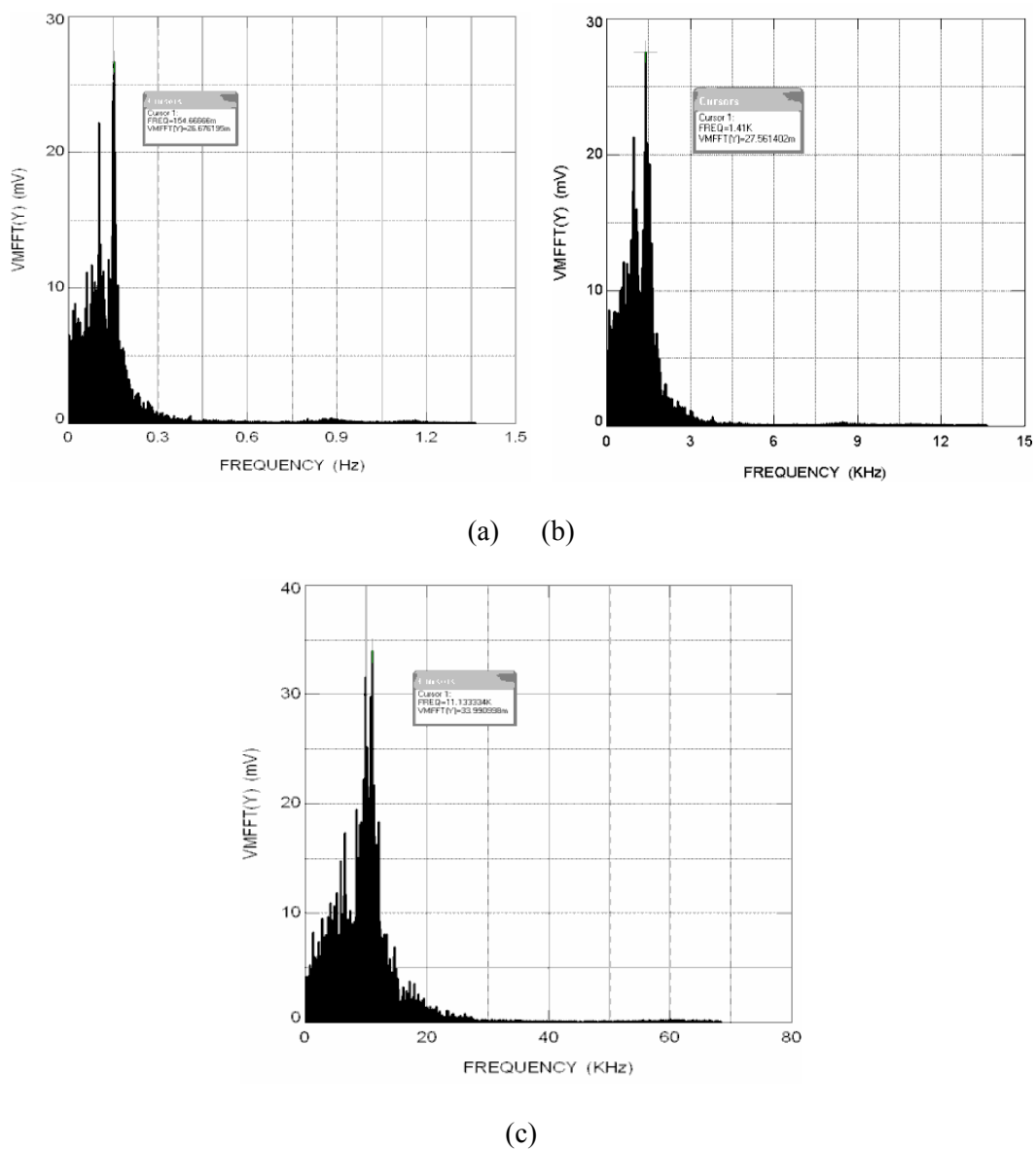

Figure 8. (a) Frequency spectrum of figure 7(b), and scaling by (b) 9533, and (c) 71500.

References

- [1] Kundert K S and Zinke O 2004 *The designer's guide to Verilog AMS* (Kluwer Academic Publishers)
- [2] Lu J, Chen G, et al 2004 *IEEE T CAS-I* **51** 2476
- [3] Yalcin M E, Ozoguz S, Suykens J A K and Vandewalle J 2001 *Electron. Lett.* **37** 147
- [4] Tlelo-Cuautle E and Muñoz-Pacheco J M 2007 *Int. J. Nonlinear Sci.* **8** 249
- [5] Ucar A and Mishra D 2006 *Int. J. Nonlinear Sci.* **7** 209
- [6] Tlelo-Cuautle E and Muñoz-Pacheco J M 2007 *Appl. Math. Comput.* **190** 1526
- [7] Tlelo-Cuautle E, Muñoz-Pacheco J M and Martínez-Carballido J 2007 *Appl. Math. Comput.* <http://dx.doi.org/10.1016/j.amc.2007.04.052>
- [8] Fang LP, Zhang H and Tong QY 2007 *Int. J. Nonlinear Sci.* **8** 59
- [9] Chen W K, Vandewalle J and Vandenberghe L 1995 *Piecewise-linear circuits and piecewise-linear analysis: Circuits and Filters Handbook* (CRC Press/IEEE Press)
- [10] Chua L O, Desoer Ch A and Kuh E S 1987 *Linear and Nonlinear Circuits* (McGraw-Hill Comp)
- [11] Matsumoto T 1984 *IEEE Trans. on CAS* **31** 1055
- [12] Tlelo-Cuautle E, Gaona-Hernández A and García-Delgado J 2006 *Analog. Integr. Circ.* **48** 159
- [13] <http://focus.ti.com/docs/prod/folders/print/tlc2262.html>.